

1 2 3 4 5 6 7 8

| REVISIONS | | |
|-----------|------|------------------------------|
| ISS | ZONE | DESCRIPTION\PER REQUEST\DATE |
| | | |

業務部

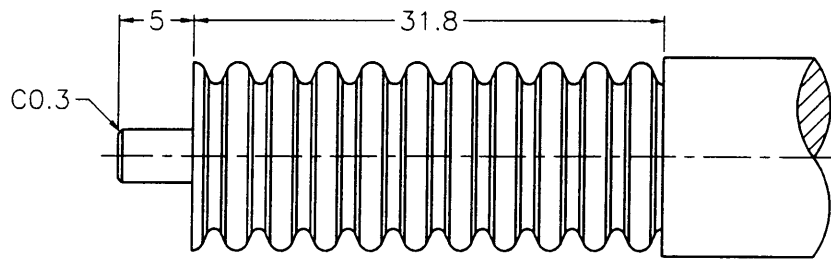

RECOMMENDED
CABLE STRIPPING DIM'S
(建議剝線尺寸)

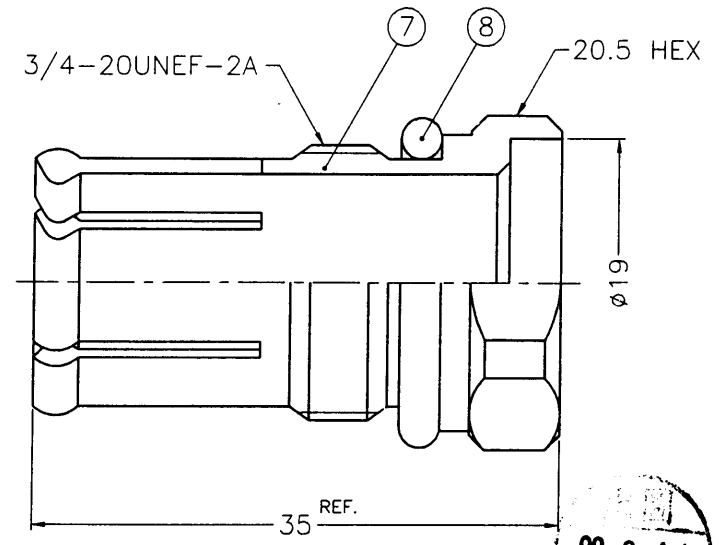
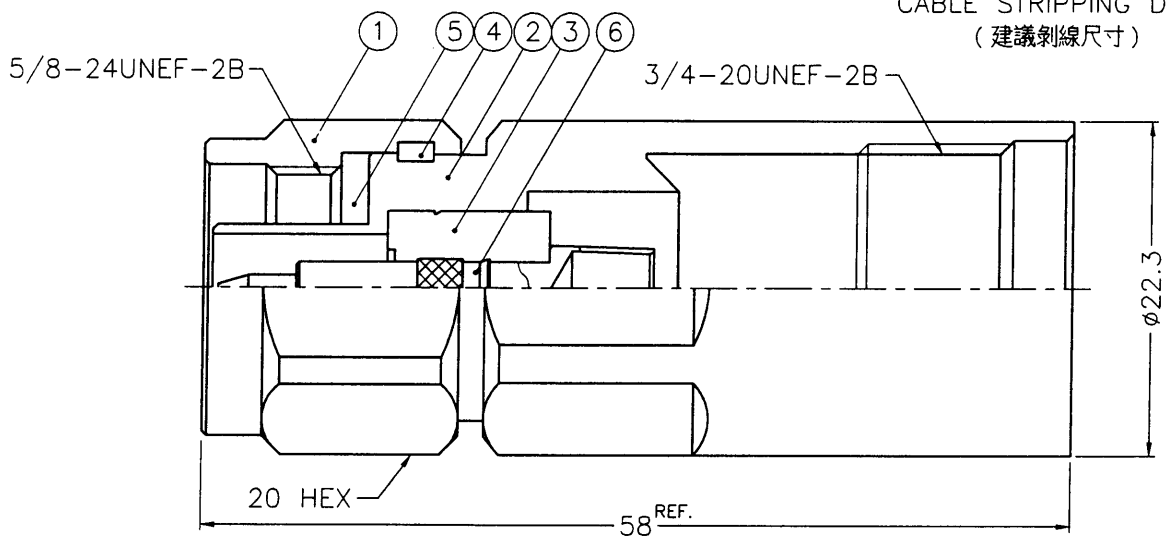
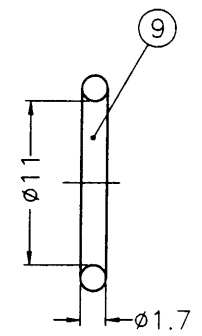

88.9.14
R & D

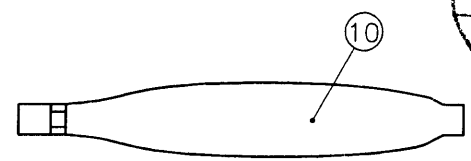

NOTES: FINISH (PLATING THICKNESS IN MICRO-INCHES)
 1. BRASS PER QQ-B-626
 2. COPPER-TIN-ZINC ALLOY
 3. SILVER PL. 200 MIN. THICK OVER COPPER STRIKE
 4. TEFLON MIL-P-19468
 5. SILICONE GREASE PER POLYTEX 55-M OR EQUIVALENT
 6. PHOSPHOR BRONZE PER QQ-B-750

| NO. | DESCRIPTION | MATERIAL | FINISH | Q'TY | DRAWING NO. |
|-----|---------------|----------|---------|------|---------------|
| 10 | LUBRICATOR | NOTE 5 | NOTE 5 | 1 | N87070302-11 |
| 9 | GASKET | SILICONE | RED | 1 | GS-144/11XD17 |
| 8 | GASKET | SILICONE | RED | 1 | GS-21/158XD26 |
| 7 | NUT | NOTE 1 | NOTE 2 | 1 | N87070302-7 |
| 6 | CONTACT PIN | NOTE 6 | NOTE 3 | 1 | N87070302-6 |
| 5 | GASKET | SILICONE | RED | 1 | GS-156/8X15 |
| 4 | RETAINER RING | SUS 304 | NATURAL | 1 | N5000-7-C |
| 3 | INSULATOR | NOTE 4 | NATURAL | 1 | N87070302-3 |
| 2 | BODY | NOTE 1 | NOTE 2 | 1 | N87070302-2 |
| 1 | SHELL | NOTE 1 | NOTE 2 | 1 | N5000-1H |

DIMENSIONS ARE IN MILLIMETERS
 UNLESS OTHERWISE SPECIFIED TOLERANCES
 0.5-6 = ±0.2
 6-30 = ±0.4
 30-120 = ±0.6
 120-315 = ±1
 315-1000 = ±1.6
 1000-2000 = ±2.4

| | |
|---------------|-----------|
| PART NO. | |
| APPROVED | DATE |
| <i>Golden</i> | 09-08-99' |
| CHECKED | DATE |
| <i>Golden</i> | 09-08-99' |
| DRAWN | DATE |
| <i>Golden</i> | 09-08-99' |

| | |
|--|--|
| Amphenol - Kai Jack | |
| TAINAN TAIWAN | |
| TITLE N CLAMP PLUG (FOR ANDREW 1/2" LDF4-50A HELIAX CABLE) | |
| DRAWING NO. KJ-N1141G1-N/NTS-1/2A-50 | |
| FILE NO. F:\DWG\N1141G1\12A\NNTS | |

F
E
D
C
B
A

F
E
D
C
B
A

1 2 3 4 5 6 7 8 8UR1806